

Icon Repair Instruction for Encapsulation Design Fittings “IRF (M-XXL)*.*” Split Repair Part Numbers

STEP 1

Identify the damaged fitting and select the proper Icon repair fitting based upon the fitting design and the pipe diameter. Icon technical support can assist in the fitting specification. Please provide pictures and other information to assist in this process.

It is important to prepare the surface where the fitting will be placed. Remove existing fitting as applicable, and remove any existing residual gasket sealant that may be in the way. Clean the surface with acetone or isopropyl alcohol to remove any contaminant that would prevent adhesion by the new gasket sealant.

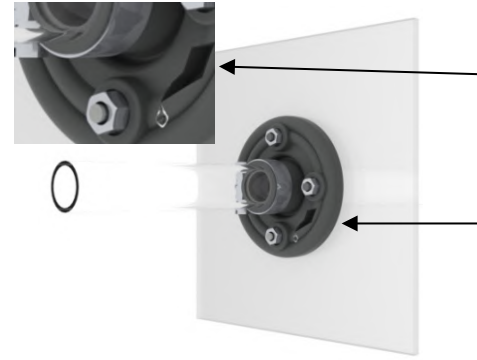

STEP 2

Assemble the split repair fitting parts over the pipe to determine the sequence of installation based upon the space you have to work with. All flexible split fitting parts except the rigid poly ring must be bonded together with FastFuse glue. This is done by first ensuring that the split surfaces are clean and dry. Apply a liberal bead of FastFuse glue to both surfaces, and then hold the seam closed securely for a minimum of two (2) minutes without movement until it is bonded sufficiently to let go. It's helpful to use the band clamps to loosely hold the seams together during the additional curing period. The FastFuse glue bond will be fully cured in 30-40 minutes.



STEP 3

Once all Icon approved split components are bonded and cured, apply a liberal bead of gasket sealant to the underside of the gasket. This will help make the seal with the sump wall. The gasket sealant products are fuel resistant, have adhesive property, and set up quickly. Keep in mind that in every Encapsulation type fitting kit, Icon supplies a “flat” and “curved” wall gasket. Make sure you are using the correct gasket for the sump type. Insert the rigid poly ring into the gasket as shown and position the ring around the old fitting and against the sump wall.

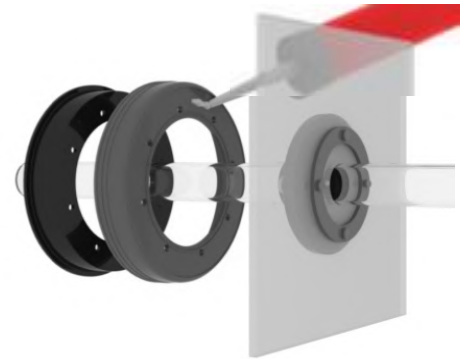

STEP 4

Install the supplied self-tapping “tec” screws through the holes in the poly ring and tighten until snug. Be careful not to over-tighten the screws, as the holes can be stripped out and you will lose the desired compression. If using a pneumatic or electric driver, be very careful, even hand tightening the last bit of the screw drive so as to not over-tighten.

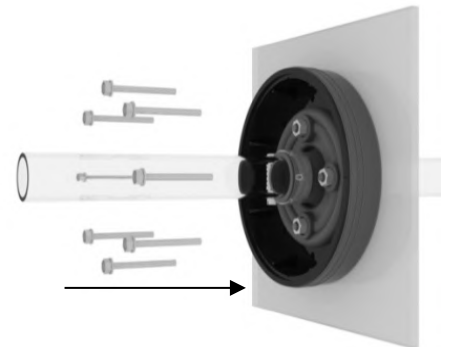

Icon Repair Instruction for Encapsulation Design Fittings “IRF (M-XXL)*.*” Split Repair Part Numbers

STEP 5

Apply a liberal amount of FastFuse glue along the gasket side wall and install the fitting boot onto the gasket. Make sure that you rotate the boot vent tube at the 12:00 position as much as possible to facilitate a better fill process. Install and tighten the band clamp securely around the boot to get a seal between boot and gasket. You do not need to wait for any cure time to continue the next steps. FastFuse glue will permanently bond the boot to the gasket during the remainder of the process.

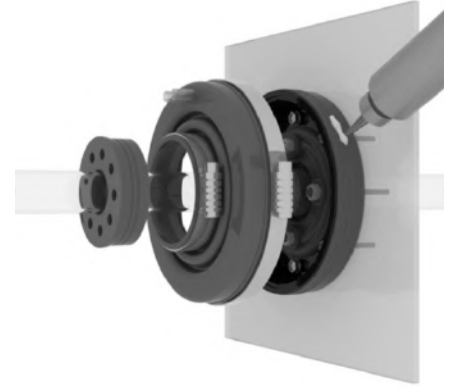

STEP 6

As applicable, apply FastFuse glue to the inside of the boot mouth and around the side of the insert, and push it into the boot mouth. Install and tighten the band clamp securely around the boot to get a seal between boot, insert, and pipe. You do not need to wait for any cure time to continue the next step. FastFuse glue will permanently bond the boot to the insert during the remainder of the process.

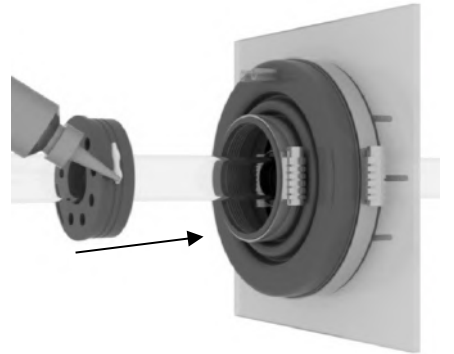

STEP 7

The Encapsulation design fittings are equipped with two tubes, one to fill through and the other to vent air out. Fill the fitting with one of the approved fill products through one of the tubes that has been aligned at the 12:00 position. Fill until the entire cavity of the boot is full and the material is beginning to come out the vent tube. Approved fill materials include Sikaflex 1a, FastFill, and PetrolSeal.

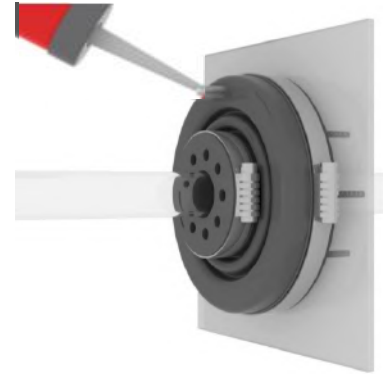

STEP 8

When completed, you may immediately start testing to confirm a successful repair. The fill and sealant may not yet be completely cured, but there is sufficient cure and seal when completed with the installation that testing may start.

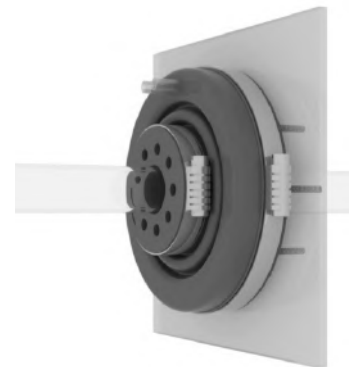

NOTE

If you have several fittings in a sump to repair, it is best to rotate the more significant repair steps in a sequence from fitting to fitting rather than try to complete the entire process with each fitting before moving on to the next. A rotation procedure will greatly decrease the time involved in a multiple fitting repair.

